

## Gear shift adjustment Saab 95/96

[www.saabv4.com](http://www.saabv4.com)

1. Loosen bolts A and B with a 1/2" ring spanner
2. Slide steering column stand up or down (arrows)
3. Check adjustment:

*Engage top gear and move the gear-shift shaft firmly but not roughly in both axial directions. When this is done the lever knob should move in the same direction as the shaft (in plane of shaft axis) 0.3–0.5in (8–12mm).*

4. Tighten bolts

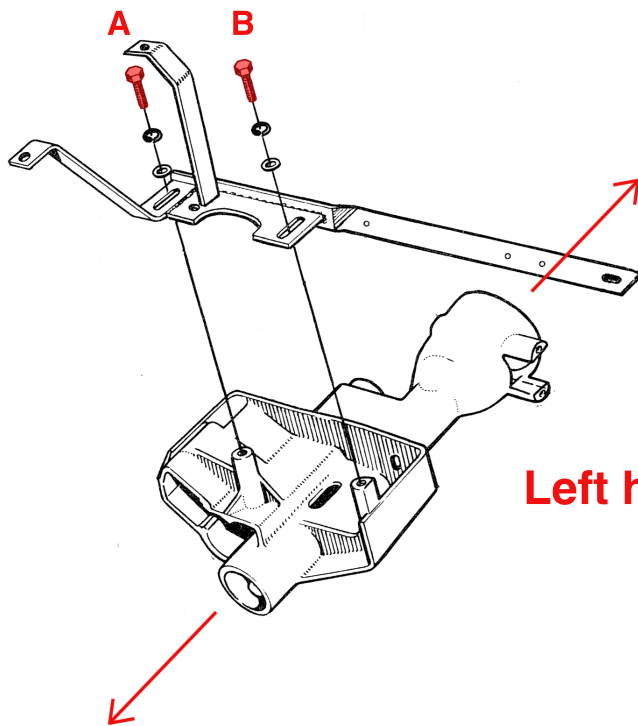

**Left hand drive**

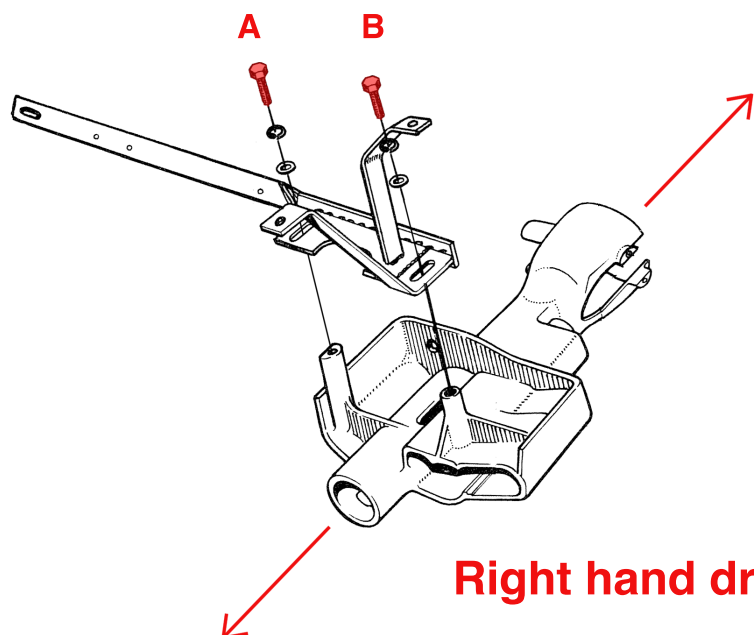

**Right hand drive**